

FWI-CKO3 700V DC Choke (Reactor)

Features:

- 1.Reducing of harmonics , Improvement of the power factor
 - 2.Reducing over-voltage extent, avoid breakdown
 - 3.Reducing the stress caused by noise to motor, extended the life span of motor
 - 4.Improvement of low-frequency conduction emission/sensitivity
-



Specifications:

- 1.Rated Voltage: DC 500V~700V
- 2.High Voltage testing: 3000VAC/50HZ/5MA/60s cored winding without arcing discharge breakdown
- 3.Switching Frequency: 0~16KHZ
- 4.Motor Frequency: 0~200HZ
- 5.Insulation Resistance: >100M, 1000VDC, cored winding
- 6.Altitude: <1000 meters
- 7.Ambient temperature: -25°C~ 40°C
- 8.Relative Humidity: <85%
- 9.Protection Class: IP00
- 10.Working Noise: <50dB(1 meter horizontal distance far away from choke)
- 11.Product Standard: GB10229-88(IEC289-1987);JB9644-1999;JB5346-1988

Housing:

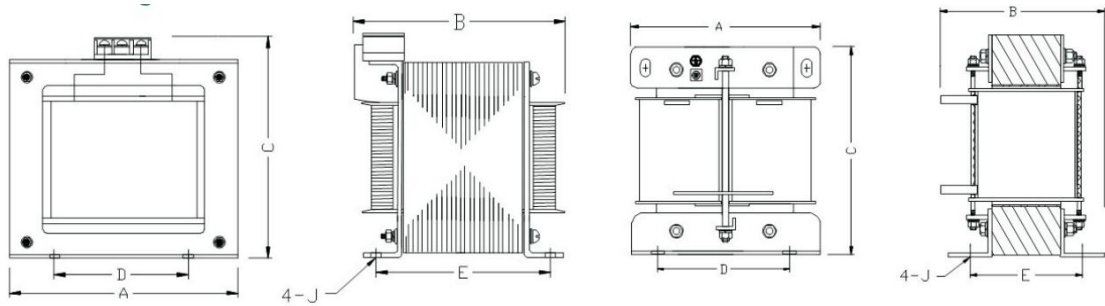

Application Diagram:

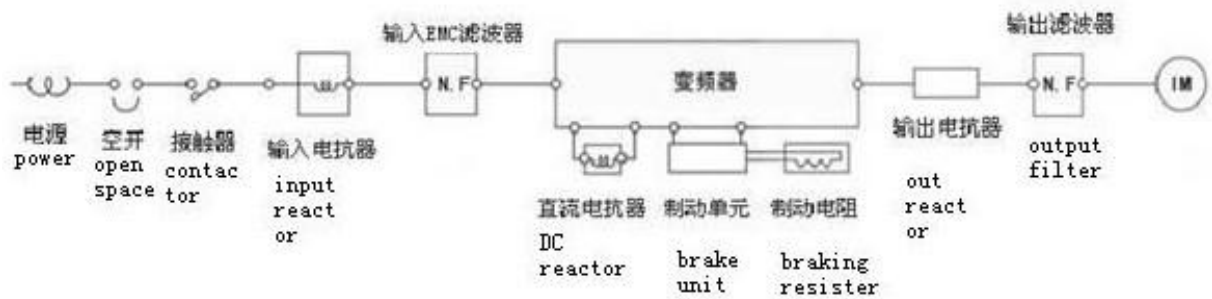



Dimension:

| Model Name | Rated Power(KW) | Outline Dimension (MM) | | | Mounting Dimension(MM) | |
|---------------|-----------------|---------------------------|-----|-----|---------------------------|-----|
| | | L | W | H | L | W |
| FWI-CKO3-d75 | 0.75 | 130 | 90 | 120 | 79 | 65 |
| FWI-CKO3-1d5 | 1.5 | 130 | 90 | 120 | 79 | 65 |
| FWI-CKO3-2d2 | 2.2 | 130 | 90 | 140 | 79 | 65 |
| FWI-CKO3-3d7 | 3.7 | 130 | 90 | 140 | 79 | 65 |
| FWI-CKO3-5d5 | 5.5 | 130 | 115 | 140 | 79 | 85 |
| FWI-CKO3-7d5 | 7.5 | 130 | 115 | 140 | 79 | 85 |
| FWI-CKO3-011 | 11 | 250 | 124 | 180 | 120 | 75 |
| FWI-CKO3-015 | 15 | 250 | 130 | 180 | 120 | 75 |
| FWI-CKO3-18d5 | 18.5 | 250 | 130 | 180 | 120 | 75 |
| FWI-CKO3-022 | 22 | 250 | 140 | 180 | 120 | 75 |
| FWI-CKO3-030 | 30 | 250 | 140 | 180 | 120 | 85 |
| FWI-CKO3-037 | 37 | 250 | 150 | 180 | 120 | 85 |
| FWI-CKO3-045 | 45 | 310 | 150 | 230 | 120 | 90 |
| FWI-CKO3-055 | 55 | 310 | 150 | 250 | 120 | 100 |
| FWI-CKO3-075 | 75 | 310 | 170 | 250 | 120 | 100 |
| FWI-CKO3-090 | 90 | 310 | 170 | 250 | 120 | 100 |
| FWI-CKO3-110 | 110 | 310 | 190 | 250 | 120 | 110 |
| FWI-CKO3-132 | 132 | 310 | 210 | 250 | 120 | 130 |
| FWI-CKO3-160 | 160 | 310 | 210 | 250 | 165 | 130 |
| FWI-CKO3-185 | 185 | 310 | 250 | 270 | 165 | 135 |
| FWI-CKO3-200 | 200 | 340 | 250 | 330 | 150 | 135 |
| FWI-CKO3-220 | 220 | 430 | 260 | 330 | 150 | 155 |
| FWI-CKO3-250 | 250 | 430 | 260 | 330 | 160 | 155 |
| FWI-CKO3-315 | 315 | 430 | 280 | 330 | 200 | 165 |
| FWI-CKO3-375 | 375 | 430 | 280 | 380 | 200 | 165 |
| FWI-CKO3-400 | 400 | 430 | 280 | 380 | 200 | 165 |